

RJC DANCE – HALO SPRING TOUR 2009 TECHNICAL REQUIREMENTS

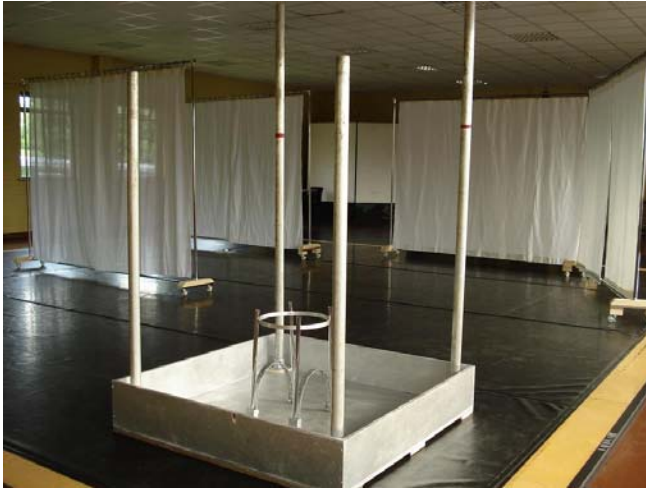

HALO is performed on a dancefloor area of 8m x 8m. If you do not have dancefloor, the company can provide it. Our set consists of four movable fabric screens, 2m high x 2.7m long which are used in different configurations during the show. We also use a 1.2m square rostrum, with fitted lighting, and three small movable

metal trolleys, two of which also house projectors, which the company will tour. Ideally we also need 4 metres clearance from the back edge of the performing area – for back projection.

Sound and visuals are run from a computer which will be installed at stage level. This station can be on stage or in the wings depending on the size of your venue, will need a feed from this computer to the front of house speakers, but we will provide the vga feeds to our own projectors.



Lighting will require 22 overhead circuits and seven floor circuits, and we would like to use four boom stands for chest and floor level lighting.

These requirements are flexible, and we are more than happy to discuss ways of making the show fit into your venue. If you have any questions, please contact our technical manager Al Orange on 07974 737329 or alorange@blueyonder.co.uk.

RJC DANCE - HALO LIGHTING PLAN - SPRING 2009

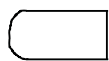
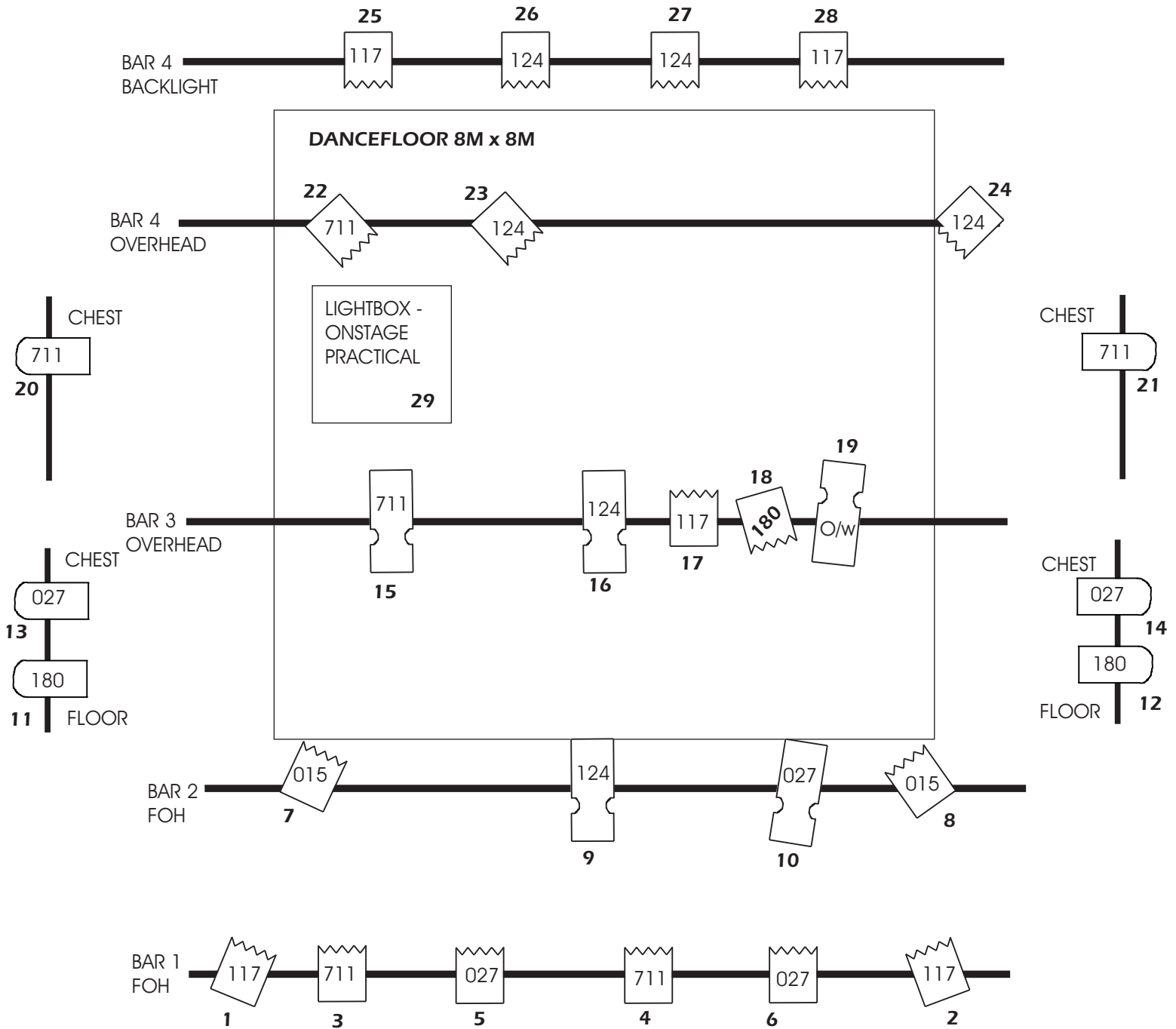

1K Parcan x 6

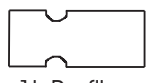

1k Profile x 4



1K Fresnel x 17

COLOURS- Lee Filters

027 - Medium Red

015 - Deep Straw

711 - Cold Blue

117 - Steel Blue

180 - Dark Lavender

124 - Dark Green

RJC DANCE - HALO FLOOR PLAN - SPRING 2009

PROJECTOR TROLLEY
13 AMP POWER SOURCE



4M IDEAL CLEARANCE
FOR BACK PROJECTION



DANCEFLOOR 8M x 8M

LIGHTBOX -
ONSTAGE
PRACTICAL
1.2M X 1.2M

DIRTBOX
1.2M X 1.2M

PROJECTOR TROLLEY
13 AMP POWER SOURCE



COMPUTER
STATION 13AMP
POWER SOURCE

